

## 15050 SERIES - BRASS GATE VALVE NPT LEAD FREE

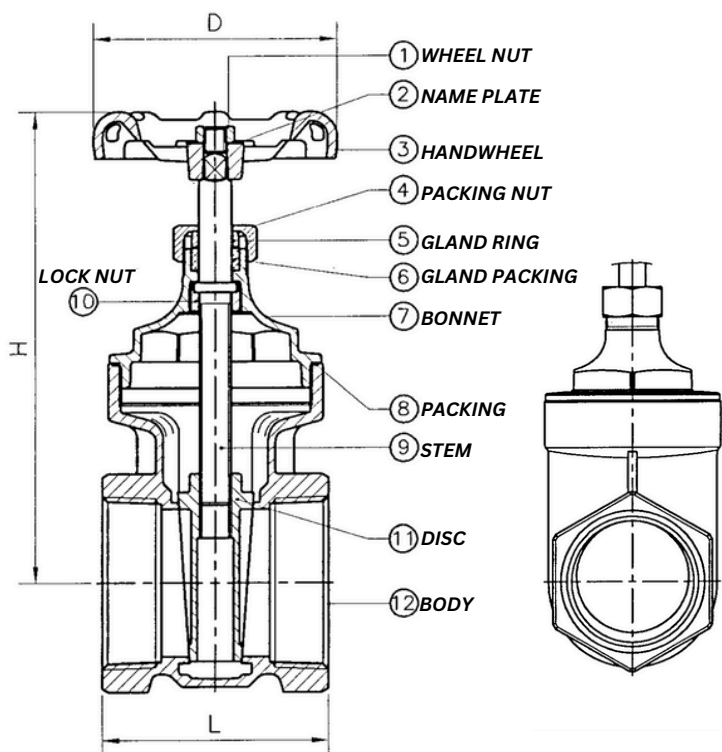

### SPECIFICATION

LEAD FREE FORGED BRASS  
 SIZE: 1/4" - 4"  
 FULL PORT  
 NPT THREAD  
 MAX TEMPERATURE RATING: 180°F  
 PRESSURE RATING: 200 PSI WOG  
 NSF/ANSI/CAN 61/372  
 GREEN HANDLE  
 ANSI B1.20.1

### COMPONENTS

N°	DESCRIPTION	MATERIAL
1	WHEEL NUT	HOT ROLLED SAE 1010R
2	NAME PLATE	ALUMINUM A1100
3	HANDWHEEL	CAST IRON JIS ZZ2202
4	PACKING NUT	BRASS RODC37700
5	GLAND RING	BRASS RODC37700
6	GLAND PACKING	NBR SN919F (2)
7	BONNET	CAST BRASS C46400
8	PACKING	FIBER "H"
9	STEM	BRASS ROD C46400 (1/4" - 2") CAST BRASS C46400 (2-1/2" - 4")
10	LOCK NUT	NBR SN919F
11	DISC	CAST BRASS C46400
12	BODY	CAST BRASS C46400

### DIMENSIONS

CODE	SIZE	D	H	L	INCHES
15050-002	1/4"	2.09	2.91	1.71	
15050-003	3/8"	2.09	2.91	1.71	
15050-005	1/2"	2.09	2.91	1.71	
15050-007	3/4"	2.13	3.31	1.81	
15050-010	1"	2.48	3.90	2.13	
15050-012	1-1/4"	2.72	4.61	2.24	
15050-015	1-1/2"	3.15	5.08	2.44	
15050-020	2"	3.52	5.98	2.70	
15050-025	2-1/2"	3.98	7.87	3.70	
15050-030	3"	4.37	8.82	4.02	
15050-040	4"	4.84	9.88	4.53	