

## 12413 SERIES

### LEAD FREE BRASS BALL VALVE FULL PORT SWT X SWT - STEEL HANDLE

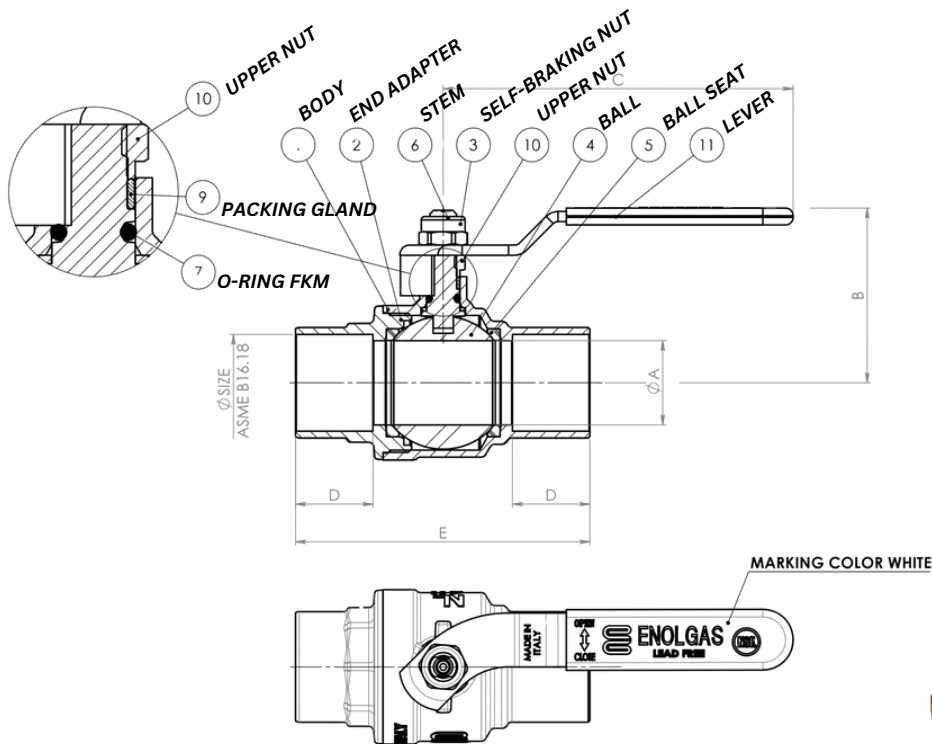

**MADE IN ITALY**

#### SPECIFICATION

LEAD FREE BRASS BODY  
 SIZES: 1/2"-2"  
 CONNECTION: SWEAT X SWEAT  
 CERTIFICATIONS: CSA | FM | NSF | LEAD FREE  
 STANDARD: ANSI  
 PRESSURE: 600 PSI  
 DIRECTION OF FLOW: IN BOTH WAYS  
 TEMPERATURE RANGE: -4° F TO 266° F  
 APPLICATION: HOT AND COLD WATER, COMPRESSED AIR,  
 OILS, ALL KINDS OF GASES, NON-AGGRESSIVE FLUIDS  
 GREEN HANDLE

#### COMPONENTS

N°	DESCRIPTION	MATERIAL
1	BODY	CW510L PB<0,1%
2	END ADAPTER	CW510L PB<0,1%
3	SELF-BRAKING NUT	AVP STEEL
4	BALL	AISI304
5	BALL SEAT	PTFE
6	STEM	CW510L PB0,1%
7	O-RING FKM	FKM
8	THRUST WASHER	PTFE
9	PACKING GLAND	PTFE
10	UPPER NUT	CW614N
11	LEVER	STEEL

#### DIMENSIONS

CODE	SIZE	DN	ØA	B	C	D	E	INCHES
12413-005	1/2"	0.59	15	1.614	3.543	0.492	2.067	
12413-007	3/4"	0.787	20	1.949	4.134	0.748	2.874	
12413-010	1"	0.984	25	2.027	4.134	0.905	3.445	
12413-012	1-1/4"	1.26	32	2.441	5.512	0.964	3.937	
12413-015	1-1/2"	1.574	38.1	2.795	5.512	1.102	4.646	
12413-020	2"	1.968	50	3.307	6.693	1.338	5.551	